

Product naming rules 产品命名规则

HL-C 2525 F35 W 3 E A (Ra1) -FC
 1 2 3 4 5 6 7 8 9 10

- 1: 鸿利光电代码
- 2: 产品系列代码
- 3: 尺寸代码
- 4: 芯片代码
- 5: 表示发光颜色为白光
- 6: 表示使用700mA分光
- 7: 模具代码
- 8: 基板材质代码
- 9: 表示显色指数
- 10: 倒装工艺

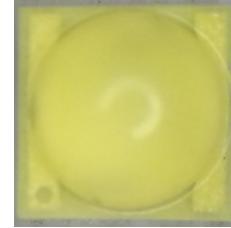

ATTENTION
OBSERVE PRECAUTIONS
FOR HANDLING
ELECTROSTATIC
DISCHARGE
SENSITIVE
DEVICES

Features 特点

- Long operating life 寿命长
- High flux 光通量高
- More energy efficient 节能
- Low voltage DC operated 低电压直流工作
- Cool beam, safe to the touch 冷光源, 接触安全
- Instant light (less than 100ns) 瞬间点亮 (小于100ns)
- No UV 无紫外线
- Flip Chip Technology 倒装芯片工艺
- RoHS compliant 符合RoHS标准



Under Development	
Mass production	●

Application range 应用范围

- Portable lightings /(flash lightings, bicycle) 便携式照明
- Working light 工作灯
- General lighting 通用照明
- Industrial lighting 工业照明
- Other lighting 其他照明

Radiation Pattern 辐射模式

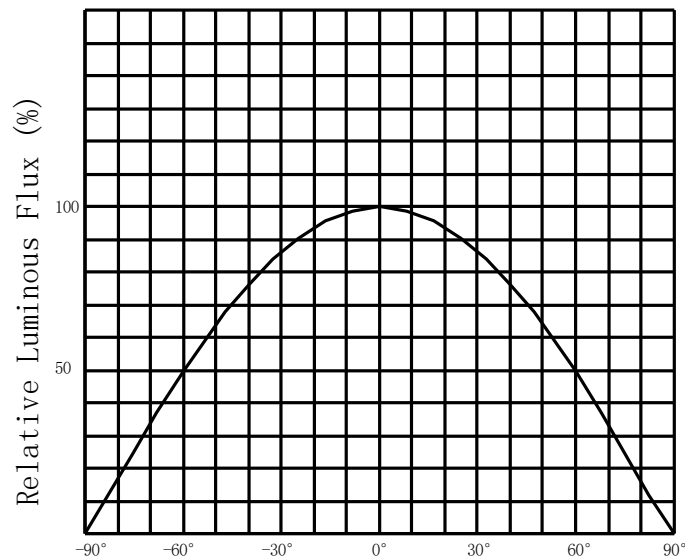
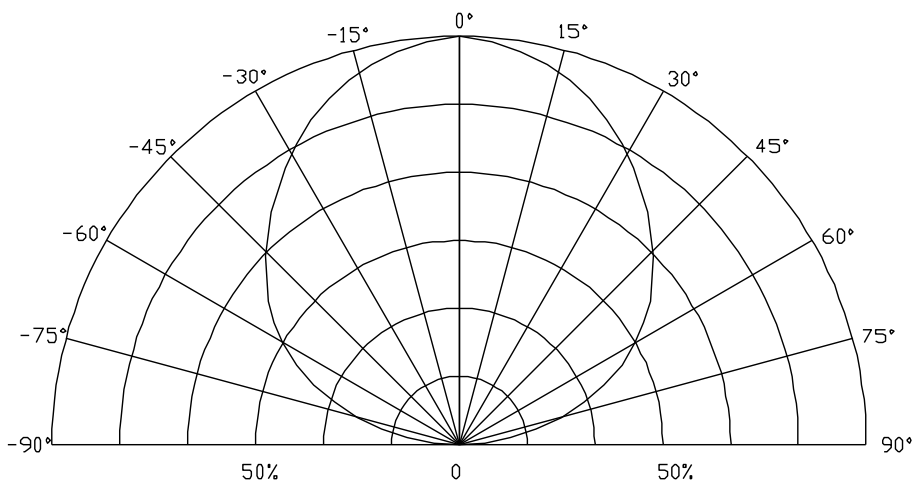

Specifications规范

(1) Absolute Maximum Ratings at Ta=25°C 在25°C时绝对极限条件

Parameter参数	Symbol符号	Rating 值	Units单位
Input power 输入功率	Pi	3.4	W
Forward Current 正向电流	I _F	1000	mA
Reverse Current反向电流	I _R	3@5V	uA
Junction Temperature结温	T _j	150	°C
View Angle (FWHM)- White 发光角度	—	120	degrees
ESD Sensitivity(HBM)抗静电能力	ESD	Class 2	
Operating Temperature Range工作温度	Topr	-35°C To +85°C	
Storage Temperature Range储藏温度	Tstg	-40°C To +100°C	
Reverse voltage 反向电压	V _r	not designed for reverse bias 不允许反向工作	

Notes注:

- * All high power emitter LED products mounted on aluminum metal-core printed circuit board, can be lighted directly, but we do not recommend lighting the high power products for more than 5 seconds without a appropriate heat dissipation equipment. When using at 700mA, TS (cathode point) temperature should be controlled below 85°C
所有高功率的发光LED产品安装在铝金属为核心印刷电路板, 可直接点亮, 但我们不建议在没有一个适当的散热设备时, 照明高功率LED点亮超过5秒, 当产品为700mA使用, TS点(负极焊盘)温度控制在85°C以下.
- wave peak and soak-stannum soldering etc.is not suitable for this products.
波峰焊、浸锡焊接不适合这个产品。
- Reflow soldering should not be done more than two times.The reflow temperature we recommend is 260°C,When the temperature exceeds 260 °C, the product failure of LED can be caused
回流焊不能超过两次, 回流焊最高温度建议260°C, 当温度超过260°C极大可能引起LED产品失效

(2) Optical Characteristics at Ta=25°C

在Ta=25°C 时的典型光学特性

Tc (K)			Ra	350mA光通量			700mA光通量		
Center Tc	Min	Max	Min	Min (lm)	Typ (lm)	Max (lm)	Min (lm)	Typ (lm)	Max (lm)
3045	2870	3220	67	130	150	170	230	260	290
3985	3710	4260	67	140	160	180	240	270	300
4025	3800	4250	67				250		290
6020	5665	6530	67	150	170	190	250	280	310
7040	6530	7560	67	150	170	190	250	280	310

Notes注:

*1.the products after this specification refer to the parameters prevail, before the release of specification without refer to the above parameters.

此规格书发布日后生产的产品以上述参数为准，发布前生产的库存品不参考上述参数。

2.Tolerance of measurement of forward voltage $\pm 3\%$ 、Color-rendering index ± 2 、luminous flux $\pm 5\%$.

不同标准源测试存在仪器公差：正向电压公差为 $\pm 3\%$ 、显指公差为 ± 2 、光通量公差为 $\pm 5\%$ 。

3.The parameters at IF=350mA are just for reference. Do not order the request parameters.

IF=350mA时的参数仅供参考，不能作为下订单时的参数要求。

4.The test is set to automatic integration, and the integral IP range is 30%~80%.

测试设置自动积分，积分IP范围30%~80%。

(3) Optical Electrical /Thermal Characteristics at Ta=25°C

在Ta=25°C 时典型的电学/热学特性

IF (mA)	VF (V)			R (j-s) (°C/W)	Po (W)
	min	typ	max		
700	2.8	3.15	3.4	8	2.2



Product bins 产品分级

(1) Forward Voltage bins 电压分级

Min (V)	Max (V)
2.8	3.0
3.0	3.2
3.2	3.4

(2) Chromaticity bins 色温分级

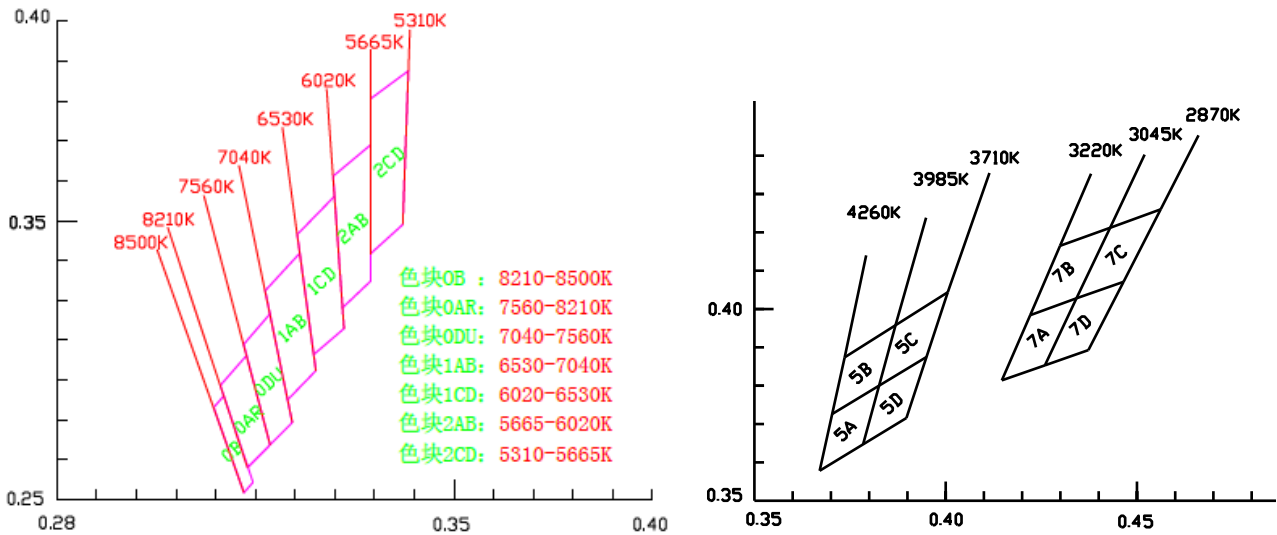

7560-8210K		7040-7560K		6530-7040K		6020-6530K		5665-6020K		3710-4260K		2870-3220K	
X	Y	X	Y	X	Y	X	Y	X	Y	X	Y	X	Y
0.2912	0.3086	0.2971	0.319	0.3025	0.3324	0.3105	0.3465	0.3219	0.3281	0.3736	0.3874	0.4298	0.4164
0.2978	0.3162	0.3036	0.3266	0.3112	0.3418	0.3199	0.3561	0.3196	0.367	0.3578	0.3612	0.4147	0.3814
0.2981	0.2881	0.3037	0.2937	0.3081	0.305	0.3147	0.3164	0.329	0.369	0.3897	0.3716	0.4373	0.3893
0.3037	0.2937	0.3093	0.2993	0.3152	0.3123	0.3223	0.3229	0.329	0.3348	0.4005	0.4044	0.4562	0.426

Notes 注:

*1.Products are tested and binned at a transient forward current(IF) with 700mA. With the use of different IF, it may probably cause differences in CCT & forward voltage. Generally, with the increase of IF, the CCT will be raised as well.

该产品通过瞬态700mA点亮, 分光分色. 若使用不同电流, 可能会引起色温及电压的变化, 一般情况下, 使用电流增加, 色温会上升。

2. Tolerance of ± 0.005 on x,y coordinates.

色坐标的测量误差允许在 ± 0.005

3.The chromaticity center refers to ANSI C78.377-2008

色温分bin参考ANSI C78.377-2008



Under Development	
Mass production	●

Typical Optical/Electrical Characteristics Curves 典型光学/电性特征曲线 ($T_s=85^\circ\text{C}$ Unless Otherwise Noted) ($T_s=85^\circ\text{C}$ 除非另有注释)

电流-相对光通量曲线

Relative Luminous Flux - IF

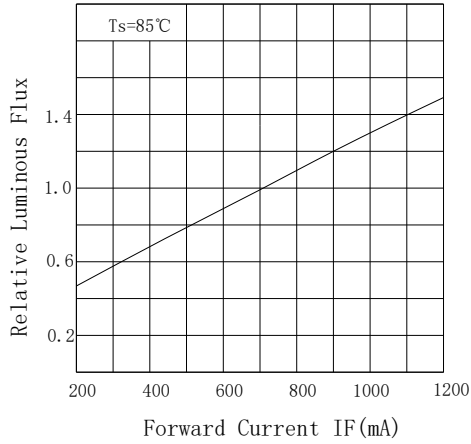

温度-正向电流曲线

Ambient Temperture- IF

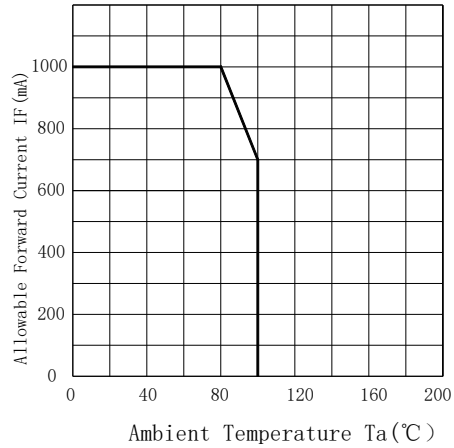

电流-正向电压曲线

IF - VF

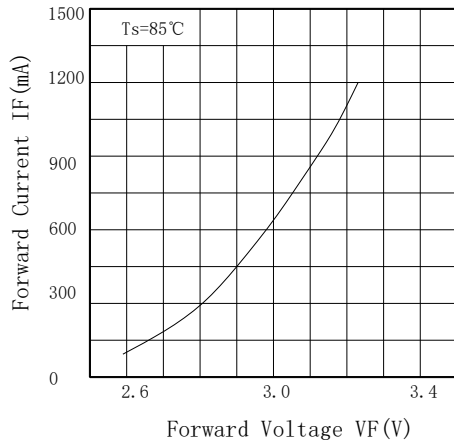

环境温度-相对光强曲线

Relative Luminous Flux - Ta

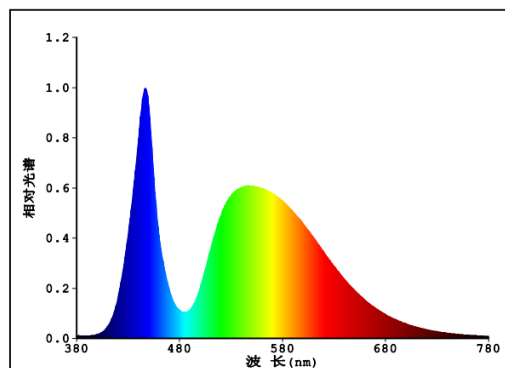
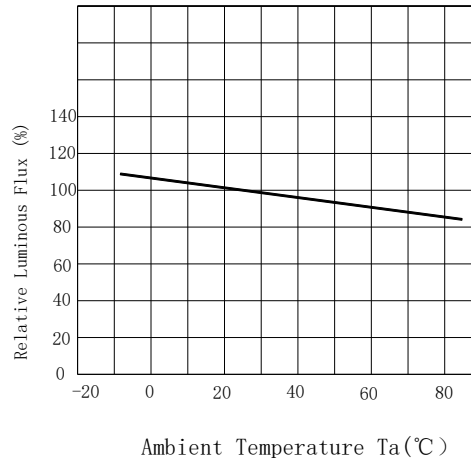



Under Development	
Mass production	●

Package Dimensions 封装尺寸

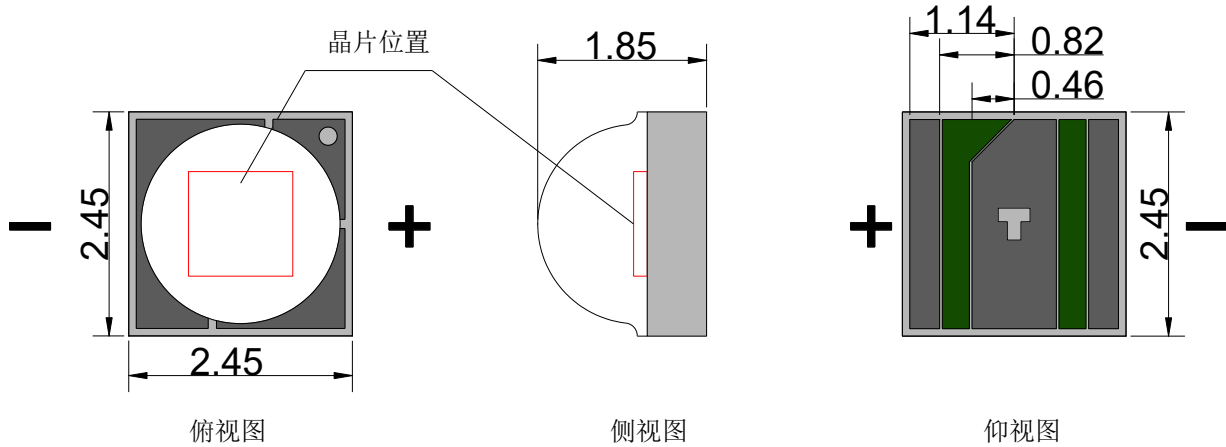

Notes 注:

- All dimension units are millimeters.
所有尺寸单位均为毫米。
- All dimension tolerance is $\pm 0.15\text{mm}$ unless otherwise noted.
所有尺寸误差是 ± 0.15 毫米除非另有说明

Welded plate and steel mesh Dimensions 焊盘及钢网尺寸

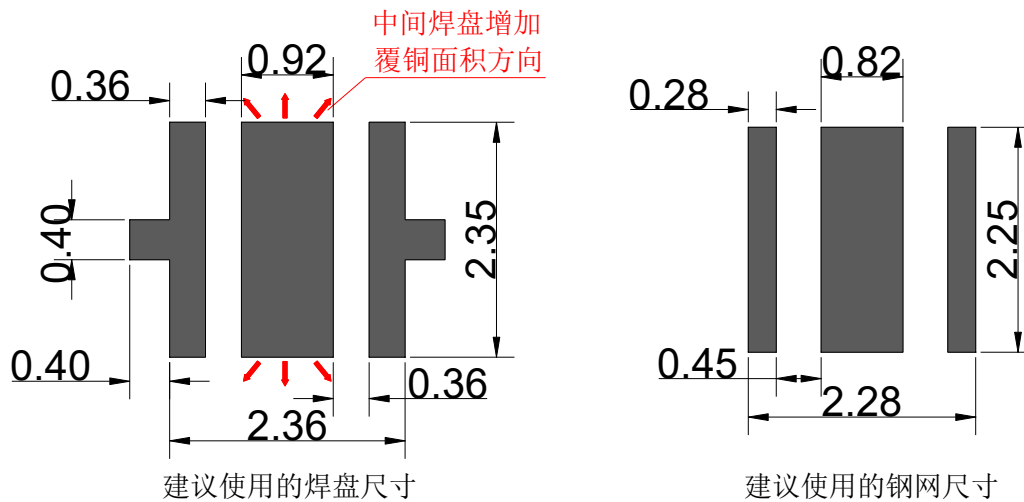

Notes 注:

When the circuit configuration is not affected, suggested the increase in the middle of the copper area, or the connection between the middle and the pad and the negative electrode can improve the cooling performance of the product.

在不影响电路配置时，建议增加中间焊盘覆铜区域，或中间焊盘和负极焊盘连接，能提高产品散热性能。



Label 标签

	HONGLITRONIC 鸿利光电	RoHS
TYPE:		QTY:
VF:	IF:	ΦV:
TC:	X/Y:	
SDCM<	Ra>	
DATE:	LOT.NO:	

Label on ESD shielding 静电袋上标签

	HONGLITRONIC 鸿利光电	成品标示卡 (Product Identity Card) RoHS
品名 (Description):		
产品型号 (Type):		
发光颜色 (Color):		
数量 (QTY):		
生产批号 (LOT NO):		
出货日期 (Date):		
操作员 (Operator):		

Label on box 外箱标签

ΦV: Luminous Flux rank 光通量档次范围

VF: Forward voltage rank 正向电压档次范围

TC: Color temperature 色温

SDCM: 相对色容差



Under Development	
Mass production	●

Tape Specifications(Units:mm)包装规格

(1)Reel package (2000 pcs/reel) 卷轴包装 (2000 pcs/卷)

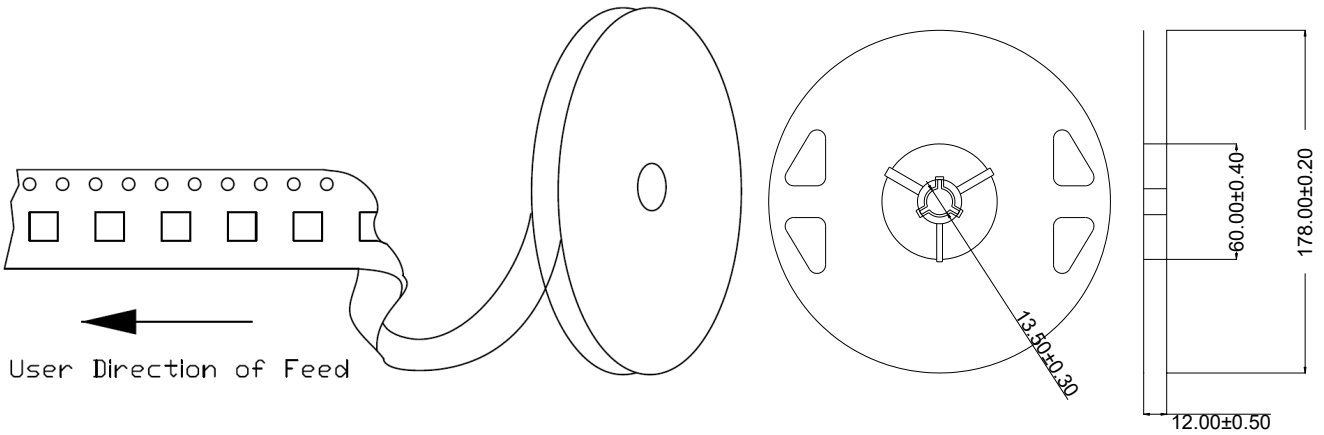
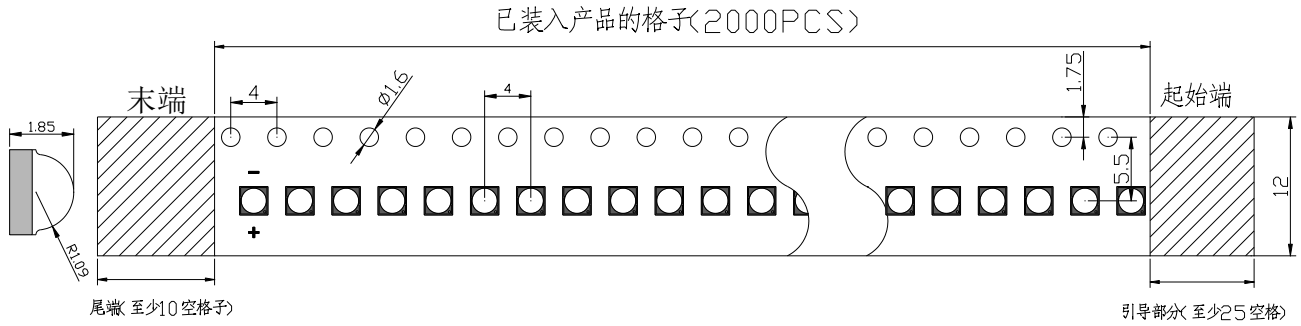

(2)Moisture resistant packaging 防潮包装

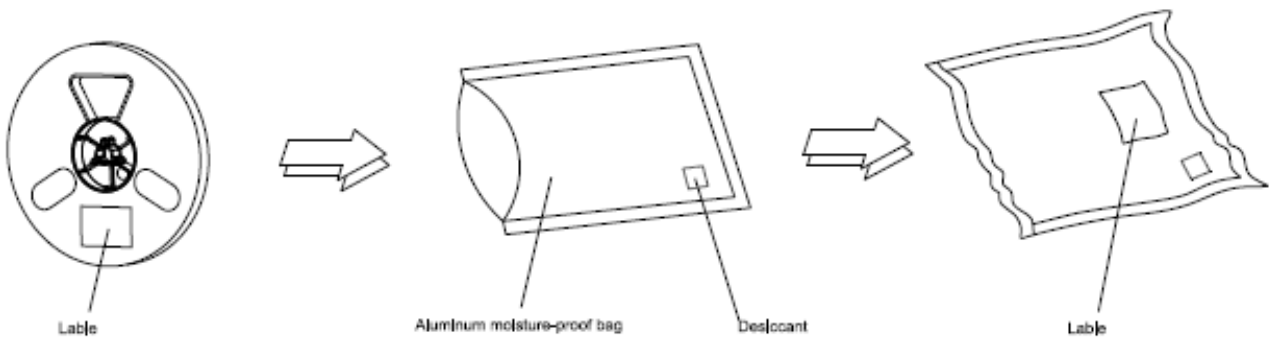



Reflow soldering instructions 回流焊说明

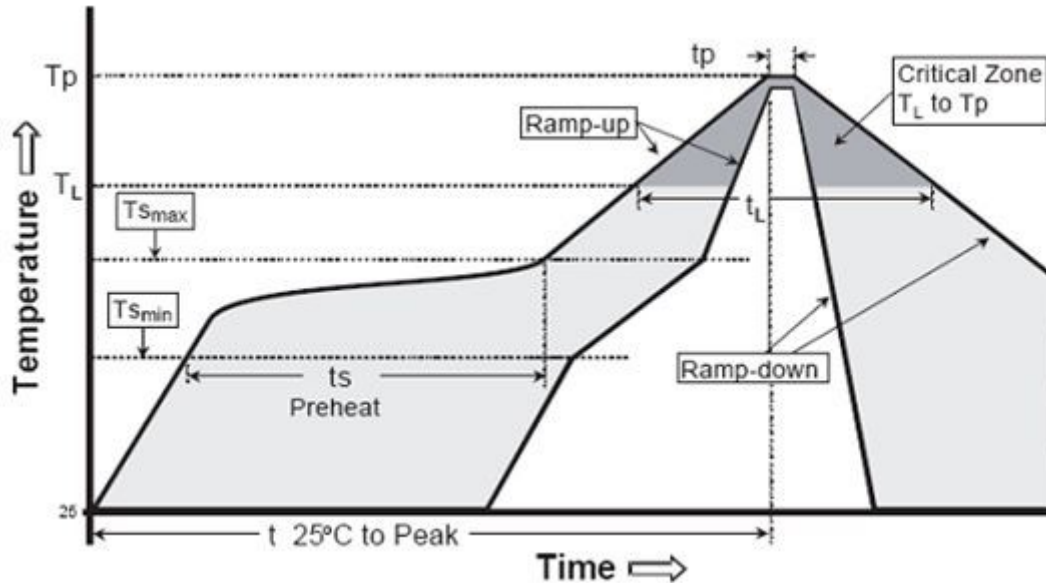

Profile Feature	Lead-Based solder	Lead-Free Solder
Average Ramp-Rate (T_{smax} to T_p)	3°C/second max	3°C/second max
Preheat: Temperature Min (T_{smin})	100°C	150°C
Preheat: Temperature Max (T_{smax})	150°C	200°C
Preheat: Time (t_{smin} to t_{smax})	60-120 seconds	60-180 seconds
Time Maintained Above: Temperature (T_L)	183°C	217°C
Time Maintained Above: Time (t_L)	60-150 seconds	60-150 seconds
Peak/Classification Temperature (T_p)	215°C	260°C
Time Within 5°C of Actual Peak Temperature (t_p)	10-15 seconds	20-40 seconds
Ramp-Down Rate	6°C/second max	6°C/second max
Time 25°C to Peak Temperature	6 minutes max	8 minutes max

Note:

1. recommend to use a convection type reflow machine with 8 zones.
建议使用八温区回流焊机。
2. recommend to use Lead-Free Paste with a melting point between 230°C-240°C.
建议使用熔点为230°C-240°C的无铅锡膏。
3. the reflow soldering time should not be more than 400s.
总的回流焊时间不要超过400s。
4. all temperature means the temperature measured on the surface of the package body.
所有温度均指在封装本体表面上测得的温度。
5. When using hot plate, the temperature is no more than 260 °C, the time is not more than 10 seconds.
当使用热板作业时，温度不超过260°C，时间不超过10秒。



Under Development	
Mass production	●

Use the matters needing attention(使用注意事项)

一、储存(storage):

为避免受潮的影响，我司建议产品在未开包装前储存条件为 5°C-30°C，相对湿度小于 60%；已开包装的 LED 光源请在 24H 内使用安装完毕，如未用完之产品，请进行除湿并抽真空后密封保存。开封超过一周或湿度卡发生变化时，请务必进行除湿，除湿条件：60°C±5°C，12H；

产品密封保存有效使用期为一年。

To avoid moisture, we recommend storage conditions for the unopened LED +5°C~ +30°C, relative humidity <60%. LED should be used within 168 Hrs. of opening the package. Please make sure to dehumidify and vacuum pack the remaining/ unused LED. Dehumidifying condition: +60°C ± 5°C, 12 Hrs. Effective age for the sealed led is one year.

二、组装注意事项(the assembly notes):

焊接条件：此产品必须使用回流焊接的作业方式，回流曲线最高温度不可超过 260°C.作业或存放过程中不可有 1000g 以上的外力或尖锐物体作用于透镜表面（如压力，摩擦等外力以及钳子镊子等工具），以免造成元件损伤；

如果超出此使用条件，鸿利光电将不能保证产品的稳定性，如需使用超出的操作条件，请务必进行风险评估。

Soldering Conditions: This product must be used reflow soldering practices, the maximum temperature of reflow should not exceed 260°C. Please make sure when soldering, there is no external force on the soldering surface (such as pressure, friction or sharp metal nails, etc.), to avoid gold wire deformation or damage and other abnormalities.

If beyond recommended conditions, we cannot guarantee the LED stability, please do the risk assessment first.

三、防静电措施(anti-Static Measures):

请采取足够的措施来防止静电产生，比如带静电环或防静电手指套等；每个制造工程关于产品（工厂、设备、机器、载波机和运输单位）应当连接地面，避免产品电气带电。

Please take adequate measures to prevent electrostatic generation, such as wearing electrostatic ring or anti-static fingerstall etc; any relative products like plant equipment, machinery, carrier and transportation units shall be connected to discharging unit/ ground. After assembly, please make sure to discharge Static Electricity with proper ESD equipment.

四、温度控制(temperature Control):

保证散热前提条件为：TS点（负极焊盘）为80摄氏度以下，在此温度以下，散热符合产品寿命要求；为确保在组装时降低接触热阻，请注意在组装过程中，散热片采用良好品质的导热膏涂布均匀且分布面积合理，不可出现太少或高低不平等现象。散热介质需保证电介质耐压测试至少通过500V。



Under Development	
Mass production	●

Recommended temperature conditions for enhanced product life: TS (Cathode Point) is $<80^{\circ}\text{C}$. During assembly, please ensure that a good quality thermal paste is applied and distributed evenly over the surface. While using thermal pad (Heat Sink), make sure LED is firmly tightened and there is no gap between surfaces. The need to ensure the cooling medium dielectric withstand test at least through 500V.

五、驱动控制 (drive control):

本产品需使用恒流源进行驱动，且输出电流符合规格书上的功率使用范围，如需使用恒压源或其他使用条件，请进行使用效果风险评估。

Drive this product at constant current. Output current range specifications should be according to the operational and other conditions, as mentioned in data sheet. Before using a constant voltage source or altered specifications, other than recommended, please consider risk factors.

六、其他 (other):

本产品不可在以下条件下使用，如果产品在以下条件下使用，评估其使用效果和风险是有必要的：

- 直接或间接的打湿或受潮，比如淋雨等；
- 被海水损害或侵蚀；
- 被暴露于腐蚀性气体(如 $\text{Cl}_2, \text{H}_2\text{S}, \text{NH}_3, \text{SO}_x, \text{NO}_x$ 等) ；
- 被暴露于粉尘、液体或油；
- 符合使用手册情况下，产品质保期为24个月，有保质协议的则以保质协议为准；
- 产品生命周期后进行回收处理。

Product is not suitable to use in following conditions;

- Direct or indirect wet / damp conditions, such as rain, etc;
- in contact with sea water and erosive materials;
- Exposed to corrosive gases (e.g., $\text{Cl}_2, \text{H}_2\text{S}, \text{NH}_3, \text{SO}_x, \text{NO}_x$, etc.);
- Exposed to dust, liquids or oils;
- In accordance with the user manual, the product shelf lift is 24 months, If there is a warranty agreement, the warranty agreement shall prevail;
- After the product life cycle for recycling.

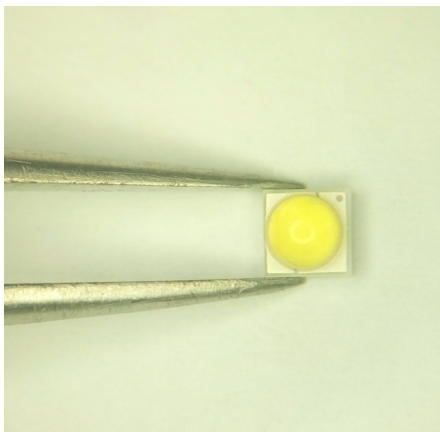

OK

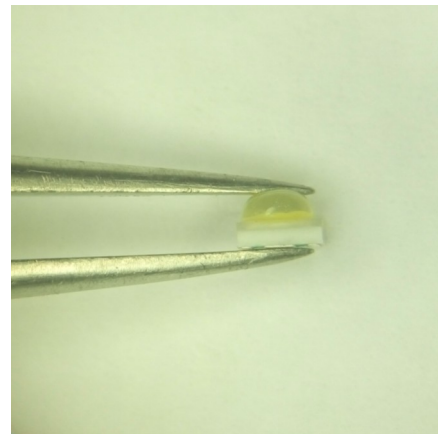

NG



修订次数	修订人	修订内容	修订日期	版次
1	梁依雯	新建文件	2019. 12. 19	A/0
2	梁依雯	更新产品封装尺寸图及公差	2020. 08. 12	A/1
3	梁依雯	增加3000K、4000K光电参数	2020. 10. 14	A/2
4	王芝烨	修改了350mA 光电参数提升	2021. 03. 14	A/3
5	李志强	更新产品尺寸误差	2021. 10. 21	A/4
6	伍学海	更新封面，修改700mA亮度，温度与正向电流曲线，Ra最小值改为67	2022. 01. 18	A/5
7	莫家强	700mA新增3800-4250K光通量250-290lm	2023. 1. 4	A/5
8				
9				
10				
11				
12				
13				
14				
15				
16				
17				
18				
19				
20				
21				
22				
23				
24				
25				
26				